



REFRIGERATED DISPLAY CASE

Neman Q



OPERATIONS MANUAL

LIMITED LIABILITY COMPANY
SNAIGE GROUP

Thank you for purchasing GOLFSTREAM refrigeration equipment

We hope you will continue choosing our products in the future. We in turn will try to meet your expectations and take into consideration all your wishes and comments on the operation of this product.

SNAIGE GROUP is continuously working on improvement of products, so we reserve the right to modify the appearance, construction elements and equipment of our products.

Detailed illustrations might not fully match your actual product and are only given to get an overall picture.

We reserve the right to revise or change the contents of this document at any time without a prior notice. Reproduction, transfer or disclosure of this document or any of its parts without prior written consent is forbidden.

This Operations Manual is aimed to make you familiar with design, installation and operation rules of the product.

Installation, startup and maintenance may only be performed by service centers of Suppliers or Sellers of **GOLFSTREAM** retail and refrigeration equipment or other enterprises authorized to perform maintenance of the equipment by the manufacturer.

 ***ATTENTION!!! PLEASE READ THIS OPERATIONS MANUAL BEFORE INSTALLATION AND BEGINNING OF OPERATION OF THE PRODUCT. ITS COMMERCIAL PAYBACK AND SAFETY DEPEND ON COMPLIANCE WITH THE REQUIREMENTS OF THIS DOCUMENT.***

CONTENTS

CONTENTS	- 3 -
INTRODUCTION	- 4 -
SAFETY MEASURES	- 5 -
GENERAL INFORMATION ABOUT THE PRODUCT	- 6 -
TECHNICAL CHARACTERISTICS	- 1 -
SCOPE OF DELIVERY	- 7 -
UNPACKING, ASSEMBLY AND PREPARATION OF PRODUCT FOR OPERATION	- 7 -
CONNECTING THE PRODUCT TO POWER SUPPLY NETWORK. SAFETY MEASURES	- 8 - ⁺
CONNECTING TO REMOTE REFRIGERATION UNIT	- 10 -
OPERATIONS AND MAINTENANCE MANUAL	- 11 -
REPLACING THE LED LAMPS	- 12 -
MAINTENANCE	- 13 -
TRANSPORTATION	- 15 -
STORAGE	- 16 -
WARRANTY OBLIGATIONS	- 16 -
DISPOSAL	- 19 -
PRODUCT DRAWING	- 20 -
ELECTRIC DIAGRAM	- 21 -
ACCEPTANCE CERTIFICATE	- 23 -
PRODUCT COMMISSIONING STATEMENT	- 24 -
MAINTENANCE RECORDS	- 25 -

INTRODUCTION

This Operations Manual (hereinafter – the Manual or OM) including nameplate data, covers Neman Q series of wall-adjacent high-temperature refrigeration display cases (cabinets) (hereinafter — the equipment, cabinet or product). The purpose of data presented below is to provide information and instruction to the consumer, information for maintenance staff regarding:

- *technical characteristics;*
- *certifications and manufacturer's guarantees;*
- *transportation and storage;*
- *installation, startup, operation (including maintenance and repair), disposal of the display case mentioned above.*

 **ATTENTION!!! THE MANUFACTURER SHALL NOT BE HELD RESPONSIBLE FOR DAMAGES CAUSED BY IMPROPER, INCORRECT USE OF THE EQUIPMENT NOT DIRECTLY SPECIFIED IN THIS MANUAL.**

SAFETY MEASURES

1. Operation and maintenance of the rack shall follow the Regulations for Operation of Consumer Electrical Installations and requirements of Labor Safety Standards.
2. Operation and installation of the display case shall only be performed by persons who have received training, instructions and examination of knowledge of safety regulations, know its design and have studied this Operations Manual.
3. Commissioning of the product should be carried out by qualified staff authorized to perform this type of works.
4. Repair of the display case can only be performed by persons with at least 3rd electrical safety qualification level who know its design.
5. The cabinet housing must be reliably grounded.
6. The consumer should provide fire extinguishing equipment and first aid kits with the required medicines and first aid measures during commissioning, repair and use of the display rack as designed.
7. Should there be any sign of unstable operation, immediately turn the cabinet off and contact a maintenance specialist.

 **Attention!**

- *List of service organizations offering commissioning and maintenance of the display case is available from the product seller.*
- *Actual commissioning of the rack shall be supported with a Commissioning Statement.*

It is strictly forbidden to:

- *Connect the rack to a power outlet without grounding;*
- *Remove frost deposits from evaporator mechanically;*
- *Wash the product with a water jet.*
- *Should there be any sign of unstable operation, immediately turn the refrigerating unit off and contact a maintenance specialist.*

 **Attention! Preparation of the product for operation, commissioning and maintenance should only be done by representatives of service organizations.**

GENERAL INFORMATION ABOUT THE PRODUCT

High-temperature cabinet for outdoor refrigeration with an evaporator and mechanical air circulation is designed for demonstration, sale and short-term storage of previously chilled food products at + 1°C to +7°C with environment temperature of +12°C to +25°C and relative air humidity not exceeding 60%.

High-temperature cabinet has a bottom exhibition surface and five (six) suspended shelves with adjustable height. Operation of the refrigerating unit is controlled by a controller.

 ***Attention! Installation, startup, maintenance and repair of products shall only be performed by specialized repair and installation companies (service centers).***

Product Commissioning Statement must be prepared based on the results of startup works. Copies of the Statement shall be provided to the dealer and manufacturer for warranty registration by the dealer's service center within 5 days. Otherwise, the dealer and manufacturer shall not bear responsibility for the warranty obligations.

Illustrations and the manual do not reflect insignificant structural modifications of products made by the manufacturer.

Products can be transported by any type of transport, except for air, only in packed condition according to the shipping rules applicable to the chosen type of transport. During automotive transport the vehicle speed should not exceed 60 km/h. Loading, transportation, unloading should be performed carefully without impacts and bumps. Box should be positioned according to the marking on it. Tilting of the box is forbidden.

Please send your feedback for improvement of operational properties and design of the product to the following address:

E-Mail: info@snaigegroup.ru

TECHNICAL CHARACTERISTICS

The main technical characteristics are presented in table:

Characteristics	Neman Q H1 125 TN	Neman Q H1 188 TN	Neman Q H1 250 TN	Neman Q H1 375 TN	Neman Q H2 125 TN	Neman Q H2 188 TN	Neman Q H2 250 TN	Neman Q H2 375 TN	Neman Q slim H1 125 TN	Neman Q slim H1 188 TN	Neman Q slim H1 250 TN	Neman Q slim H1 375 TN	Neman Q slim H2 125 TN	Neman Q slim H2 188 TN	Neman Q slim H2 250 TN	Neman Q slim H2 375 TN	Neman Q X-slim H1 125 TN	Neman Q X-slim H1 188 TN	Neman Q X-slim H1 250 TN	Neman Q X-slim H1 375 TN
Length (with side panels), mm	1252 (1332)	1877 (1957)	2502 (2582)	3752 (3832)	1252 (1332)	1877 (1957)	2502 (2582)	3752 (3832)	1252 (1332)	1877 (1957)	2502 (2582)	3752 (3832)	1252 (1332)	1877 (1957)	2502 (2582)	3752 (3832)	1252 (1332)	1877 (1957)	2502 (2582)	3752 (3832)
Width, mm	1000				1000				850				850				700			
Height, mm	2000				2200				2000				2200				2000			
Display depth on suspended shelves, mm	600				600				500				500				400			
Exhibition area, m ²	4.75	7.13	9.50	14.25	5.50	8.25	11.00	16.50	3.89	5.83	7.78	11.66	4.51	6.77	9.03	13.54	3.08	4.61	6.15	9.23
Useful volume, m ³	1.21	1.81	2.42	3.62	1.36	2.04	2.72	4.07	1.01	1.51	2.01	3.02	1.13	1.70	2.01	3.39	0.81	1.21	1.61	2.42
Display depth on the bottom exhibition shelf, mm	800								610								460			
Maximum load per shelf, kg/m ²	160																			
Useful volume temperature	from +1 °C to +7 °C																			
Refrigerating capacity (-10/+45°C), kW	1.5	2.3	3.1	4.6	1.5	2.3	3.1	4.6	1.4	2.2	3.0	4.5	1.4	2.2	3.0	4.5	1.2	1.9	2.5	3.7
Daily electrical energy consumption, kWh, max.	1.7	2.55	3.4	5.1	1.7	2.55	3.4	5.1	1.7	2.55	3.4	5.1	1.7	2.55	3.4	5.1	1.7	2.55	3.4	5.1
Nominal power, W	110	166	221	331	110	166	221	331	110	166	221	331	110	166	221	331	110	166	221	331
Illumination, W	20	30	40	60	20	30	40	60	20	30	40	60	20	30	40	60	20	30	40	60
Control device	Electronic controller																			
Defrosting	Natural																			
Current type	AC, single phase																			
Frequency, Hz	50																			
Nominal voltage, V	230																			
Noise level	below 65 dB																			
Refrigerant	R 452A																			
Overall dimensions with packaging, mm																				
-length	1370	2000	2630	3870	1370	2000	2630	3870	1370	2000	2630	3870	1370	2000	2630	3870	1370	2000	2630	3870
-depth	1200								1050								900			
-height	2200				2350				2200				2350				2200			
Net weight, kg	175	260	330	485	187	280	355	520	160	240	305	445	170	255	325	475	145	215	275	400
Gross weight, kg	269	372	464	648	285	397	495	688	251	350	436	604	265	369	461	639	233	322	403	555

SCOPE OF DELIVERY

The delivery set of products is presented in table:

Name	Neman Q H1/ Slim H1/X- Slim H1 1250	Neman Q H1/ Slim H1/X- Slim H1 1875	Neman Q H1/ Slim H1/X- Slim H1 2500	Neman Q H1/Slim H1/X- Slim H1 3750	Neman Q H2/Slim H2 1250	Neman Q H2/Sli m H2 1875	Neman Q H2/Sli m H2 2500	Neman Q H2/Sli m H2 3750
Assembled display case	1	1	1	1	1	1	1	1
Suspended shelf	5	10	10	15	6	12	12	18
Suspended shelf bracket	10	20	20	30	12	24	24	36
Manual	1	1	1	1	1	1	1	1
Packing list	1	1	1	1	1	1	1	1
Exhibition shelf	2	3	4	6	2	3	4	6

UNPACKING, ASSEMBLY AND PREPARATION OF PRODUCT FOR OPERATION

 **Attention!** Installation, connection to remote unit, startup, maintenance and repair of products shall only be performed by specialized repair and installation companies (service centers).

1. Carefully remove packing materials from the product, taking precautions to avoid mechanical damages of the product surface panels.

• *Should you find any mechanical damages, contact a service organization representative and, if needed, prepare a corresponding statement.*

2. Remove components and documentation from the inside space. Read the data sheet. Check for completeness and absence of damages.

3. The product should be moved inside the premises on a pallet or by the enclosure.

• *Do not pull the product by side elements to prevent tearing them from the enclosure!*

• *Do not move the product by a forklift without a pallet to prevent damages to refrigeration and electrical systems!*

4. Unscrew the fastening bolts and remove the product from wooden pallet. Screw the supports into their designated places.

Get the product into stable horizontal position by adjusting the supports; this ensures noiseless operation of the product and proper condensate collection.

•Do not install the product near heating appliances – closer than 2 m, in direct sunlight, in the path of draughts caused by opening of doors, windows or climate control systems, in rooms with high humidity! Otherwise, the operating parameters will be lower, the product may break down, and warranty obligations in this case will not apply.

5. Assembly of the product:

1. Remove packaging from suspended shelves, brackets, supports and self-tapping screws, siphon pipe, screen, base.
2. Install the siphon pipe.
3. Install the base.
4. Install brackets into slots in racks on the same height.
5. Install the shelves on installed brackets.
6. Install the screen.

If the product was stored or transported at temperatures below +12°C, it has to be kept at a temperature above +12°C for at least 12 hours before connecting to the power network.

 **Attention! Do not plug unheated device into power network. This can lead to jamming of the compressor or breakdown of the product.**

CONNECTING THE PRODUCT TO POWER SUPPLY NETWORK. SAFETY MEASURES

Electrical equipment of the product complies with the safety norms stipulated in standards GOST 23833, GOST R IEC 60335-2-24. Refrigerating unit electric circuit includes protection from lengthy overloads.

Display case should be connected to power supply network in accordance with the current Electrical Installation Regulations and Safety Norms.

Network supply voltage should be within minus 10% to plus 10% range of the nominal with permitted current frequency fluctuations according to GOST 32144.

 **Attention! If network supply voltage fluctuations in your region exceed the specified limits, it is recommended to connect the product through a voltage monitor. Otherwise, the product may break down, and warranty obligations in this case will not apply.**

The product is equipped with a power cord with ground wire and a power plug with ground contact; network protection wire is connected to it through the grounding contact of the power outlet.

The product may only be connected to a power outlet with a ground contact connected to the network grounding circuit.

The product must be grounded, the ground has to be connected to a ground clamp in the machine compartment (see wiring diagram). The ground circuit has to be checked regularly.

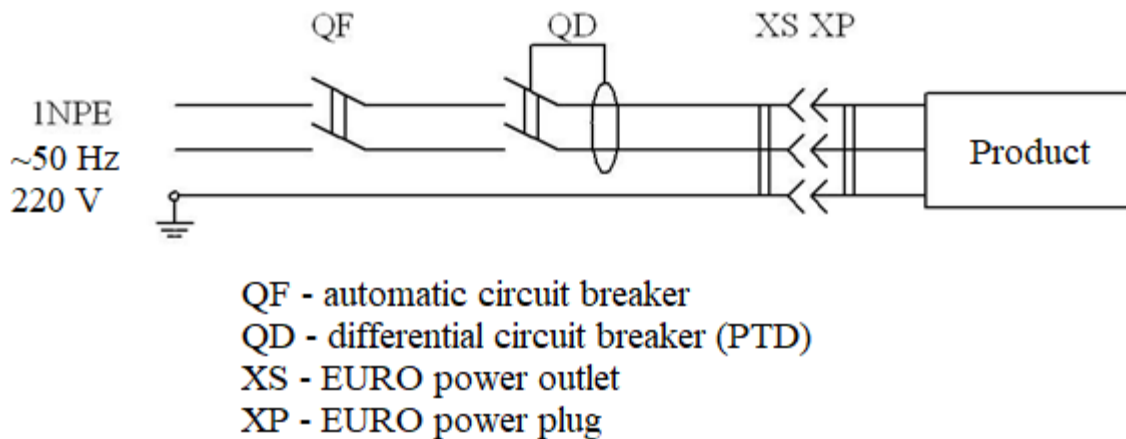

⚠ Attention! Ratings of protective devices should be selected according to the tabular data for the corresponding product

⚠ Attention! Connection of the display case to power supply network should only be done by qualified specialists. Connection to the power supply network should be done in accordance with the current safety norms.

⚠ Attention! Operation of the equipment with missing or faulty grounding, without automatic circuit breaker, with removed or faulty automation devices, as well as with damaged insulation of electric wires, with removed or open machine compartment panels, with glass enclosure with sharp edges and damages is forbidden. Otherwise, the product may break down, and warranty obligations in this case will not apply.

⚠ Attention! The product has to be connected to power supply network through EMP automatic breaker and a differential breaker (PTD).

⚠ Attention! Installation of PTD (protective tripping device) is mandatory in combination with circuit breaker with thermal or electromagnetic releases. Such system for protection from short circuit and leak currents, composed of PTD and circuit

breaker, must be designed for the total current consumed by the equipment being protected.

Main requirements for the protection system:

- PTD must be protected from network overloads (thermal protection through use of a breaker);
- circuit breaker must have sufficient resistance to short-circuit current relative to PTD;
- protection system must have selectivity in an emergency situation.

The individual type of PTD should be selected according to the current consumption depending on the number of protected equipment and differential current based on the specific type of discriminating protective system.

To ensure proper operation of electrical equipment deviation of the network voltage from the nominal value should not exceed $\pm 10\%$. Network voltage should also be monitored in the process of the display case operation.

The display case should be connected to the power supply network through a separate thermal-magnetic circuit breaker in the power distribution board, which performs the functions of a safety device and main breaker of the display case. After all the equipment is connected, the power supply system has to be checked for peak (maximum) load. To do this make sure that all the electrical equipment turns back on after interruption of power supply and does not trip circuit breakers. Otherwise the power supply system has to be modified to differentiate startup of equipment.

 ***Attention! Installation, startup, maintenance and repair of products shall only be performed by specialized repair and installation companies (service centers).***

CONNECTING TO REMOTE REFRIGERATION UNIT

 ***Attention! All work required to connect the product to the remote refrigeration unit must be performed only by qualified specialists.***

The product connects to the piping system leading to the remote refrigeration unit using copper piping.

The connection of the pipelines must be done by brazing. The pipe connection must be tight. The suction pipe must be insulated with K-flex insulation to prevent condensation and frost from forming on the piping.

The diameter of the liquid line of the showcase is 3/8", the diameter of the suction line is 1/2".

OPERATIONS AND MAINTENANCE MANUAL

1. Service life of the product and safety of its operation depends on observance of the operation rules and requirements of this data sheet.
2. The product meets its operational characteristics when operates in premises where temperature and relative humidity do not exceed, respectively: +25°C and 60% RH, and the installation location follows the rules listed above. Otherwise, the operational characteristics will be lower, which can result in spoilage of food products. The product may break down, and warranty obligations in this case will not apply.
3. After connection of the product to power network pursuant to the rules presented above you can start it up from the control panel.

The control panel is shown in Figure 2.

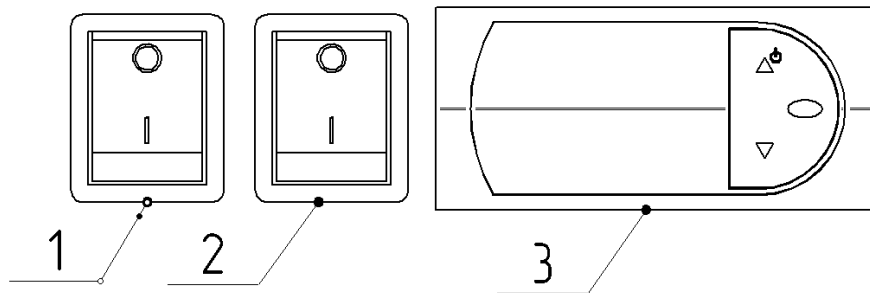

Figure 2. Control panel with controller

1. Light switch;
2. OFF button;
3. Controller device

⚠ Attention! The controller is used for automatic maintenance of preset temperature in the refrigerated volume and control of the evaporator defrosting process. The factory settings provide for the optimal product operation mode. Readjustment of the controller must only be done by service organization workers.

4. Before loading the refrigerated volume of the device with food products connect the device to power network and wait for the temperature of refrigerated volume to reach the required value.

⚠ Attention! Load the device with chilled products, placing them on shelves evenly and not exceeding the maximum permitted load.

⚠ Attention! Do not close the air intake openings with products.

⚠ Attention! Distance between products and back hinged panels should be at least 2 cm.

 **Attention!** *Failure to meet these requirements leads to disruption of air circulation, deterioration of the operational characteristics of the product, which can result in increasing temperature of food products and faster development of frost on evaporator, breakdown of the equipment.*

 **Attention!** *Do not store inside the product explosive substances and such objects as aerosol cans with flammable mixtures.*

5. Fogging of glass enclosure of the product can occur when air humidity exceeds 60% or when the ambient temperature exceeds 25°C, and is not considered a defect.

6. A person appointed by the company director is responsible for maintenance, its arrangement and timely repairs.

7. Operation of the product is only allowed for persons who have received safety instructions and know the product handling rules.

8. Workers of the company where the product is installed can perform the following works that do not require tools and dismantlement:

a) monitoring of temperature in the refrigerated volume;

b) monitoring of condition of the product, its proper loading, condensate drain system;

c) visual inspection of evaporator (air cooler) for presence of excessive frost deposits;

d) inner surfaces and dismantled parts of equipment have to be washed with soft detergent than rinsed with clean warm water and wiped dry with a soft rag **at least once a week**, after which the equipment has to be left overnight for ventilation.

 **Attention!** *Only perform cleaning (washing) of unloaded and disconnected from power supply network product (power cord plug has to be removed from the outlet of fixed wiring network).*

 **Attention!** *If the product is equipped with doors, they have to be opened for ventilation.*

Attention! *In case of any signs of faulty operation of the product or any traces of halon leak immediately disconnect the product from the power supply network and call a representative of a specialized service organization (dealer's service center).*

REPLACING THE LED LAMPS

The lighting inside the cabinet is obtained by LED lamps that allow:

- to reduce lighting consumption
- to reduce rated power

- duration of the lights for more than 6 years
- instant power on

LEDs replacement

1. remove electric power supply to the cabinet
2. turn bulb D by about 90° (until it clicks) and pull it out from the bulb-holder
3. replace the bulb with an identical one
4. restore electrical power supply

MAINTENANCE

 **Attention!** *Keeping the product in proper operating shape requires monthly maintenance by a service organization. A person appointed by the company director is responsible for preparation and organization of maintenance and timely repair of the product.*

Maintenance must include the following mandatory works:

- a) visual inspection of completeness and technical condition of the product;
- b) check of presence and status of grounding system, its components and connections, check of transient resistance between the ground clamp of the rack and accessible metal parts of the rack, which should not exceed 0.1 Ohm;
- c) lighting system operation check;
- d) check of automatic defrost of evaporator and condensate drain;
- e) check of tightness of refrigeration system;
- f) check of leak currents, which should not exceed 3.5 mA.

During the works described in paragraphs a), b), e), f), g) the product has to be disconnected from the power supply network (by pulling power cord plug from power outlet).

In case of damages to power cord or malfunction of lighting fixtures they have to be replaced by a service company specialist.

 **Attention!** *Every maintenance has to be recorded in OM.*

Maintenance work includes maintenance during use, routine maintenance and current repair of equipment.

Maintenance during use includes the works related to cleaning of the product.

Routine maintenance and current repair of the product can be performed by persons holding a document confirming their right to perform repairs – retail and process equipment installation and repair specialists.

Maintenance information should be recorded in an accounting document.

Routine maintenance and current repair are performed according to the following repair cycle:

5 MT - CR...- 5 MT

where MT – maintenance

CR – current repair

MT is performed once a month

CR is performed once every six months.

List of preventive maintenance works required during servicing of refrigeration equipment with connection to external refrigerating unit:

- insulation resistance measurement;
- visual inspection of technical condition of equipment;
- visual inspection of automation assemblies for absence of external damages and reliability of fixation;
- cleaning of defrost water drain system;
- check of tightness of refrigeration system;
- technical inspection of electrical equipment, checking of tightness of contact of electrical devices and reliability of connection of ground wires to the grounding bolt;
- check and adjustment of control devices;
- check and adjustment of operating parameters of refrigerated display case in accordance with the data sheet specifications.

List of preventive maintenance works required during servicing of refrigeration equipment:

- visual inspection of technical condition of equipment;
- visual inspection of automation assemblies for absence of external damages and reliability of fixation;
- cleaning of defrost water drain system;
- cleaning of refrigeration unit components from pollution;
- cleaning of electrical equipment;
- check of tightness of refrigeration system;

 ***Attention! Disruption of tightness of the system with refrigerant circulating in it (for any reason) can result in refrigerant leak and getting into eyes and on skin. Fast evaporation of liquid refrigerant can cause cold burn.***

- technical inspection of electrical equipment, checking of tightness of contact of electrical devices and reliability of connection of ground wires to the grounding bolt;
- check and adjustment of control devices;
- check and adjustment of operating parameters of cabinet in accordance with the data sheet specifications.

List of maintenance works required during current repair of refrigeration equipment with connection to external refrigerating unit:

- performance of works required by maintenance;
- check of tightness of electrical contact connections;
- check of resistance between ground clamps and metal parts of the equipment that may end up being energized in case of insulation break.

Based on inspection results:

- elimination of freon leak and replenishment of freon in the system;
- replacement of automation devices and refrigeration fittings (thermovalve, solenoid valve, etc.).

 ***Attention! Do not use any refrigerant other than specified in the OM.***

 ***Attention! Alterations of the display case electrical circuit are not allowed and will result in cancellation of warranty obligations.***

 ***Attention! The product has to be disconnected from power supply network during maintenance, fault correction and sanitary treatment operations.***

 ***Attention! Correction of faults should be performed only by a specialized organization (dealer's service center).***

Utilization of thermal insulation material - polyurethane foam, after expiration of the service life and writing off by burning is not allowed. For proper disposal, equipment has to be buried at minimum two meter depth at a special dumpsite.

TRANSPORTATION

Packaged product can be transported by all types of transport, except for air, pursuant to the cargo haulage rules in effect for such type of transport.

STORAGE

Before being put for storage the product has to be cleaned, washed and dried.

During storage the product has to be deenergized, covered from dust and direct sunlight.

Temperature in a room where the product is stored should not be below -35°C or above +40°C, relative humidity – not exceeding 70%. Vibration of the floor or rack where the product is stored is not allowed.

WARRANTY OBLIGATIONS

The factory guarantees proper operation of the equipment subject to compliance with the operation and installation requirements, and if installation was done by a subcontractor organization authorized by the manufacturing plant.

A mandatory condition for an event to be considered a warranty event is strict observance of the operating conditions by the Owner, as specified in the Operations Manual and other documents delivered to the user together with the product.

Elimination of identified defects and replacement of faulty components of the product during the warranty operation period must be done by service organizations.

The warranty is valid subject to maintenance of the product. Warranty obligations do not include maintenance during the warranty period. Maintenance is a charged service provided by a service organization.

During startup works the buyer must conclude an agreement with a service organization for maintenance of the product.

Warranty obligations are valid if the buyer has the following documents:

- Manuals for the product;
- Product Commissioning Statement;
- Agreement with a service organization for maintenance works.

The statements have to get signed by the Buyer, service organization representative and certified with the corresponding seals.

Please thoroughly read the Operating Instructions before using the product.

Warranty shall not be provided in the following cases:

- violation of the operating conditions, as specified in the Operating Instructions and other documents delivered to the user together with the product;
- if the product has signs of attempts to open, repair equipment by the user, if warranty seals are broken (if used);

- if malfunction is caused by unauthorized alteration of the product design or construction, not permitted by the manufacturer;
- if malfunction is caused by nonconformity of supply network parameters to the standards;
- if the product has mechanical damages;
- if damages are caused by operation of the product in conditions exceeding the specified IP rating;
- if damages are caused by penetration of dirt or moisture between the contacts of outlets on the control panel, power supply unit and high-frequency cable - for products with any IP rating;
- in case of identification of damages caused by high or low temperatures that exceed the range specified in the product documentation, corrosion, oxidation, penetration of foreign objects, substances, liquids, animals, insects inside the product, the protection from which is not guaranteed by the manufacturer;
- if the product serial number is destroyed or illegible;
- if the defect is caused force majeure circumstances, accidents, natural disasters, intentional or careless actions of the user or third parties;
- if configuration of the product does not match factory supply.
- if the Owner performs repair or replacement of assemblies, components, materials on his own or with engagement of persons who were not authorized by the manufacturer;
- local corrosion damages due to natural aging or in places of paint chips, as well as abrasive impact on coating from small rocks, sand, etc.;
- broken, cracked or scratched decorative parts, their discoloration, if it was not caused by a defect in materials or factory workmanship.
- operation of the product does not match the requirements specified in this Manual;
- parts and components have damages resulting from non-observance of transportation, handling, storage, startup, operation rules;
- damages caused by incorrect connection, operation in abnormal conditions or in conditions not specified by the manufacturer;
- damages are caused by excessive fluctuations in the power supply network;
- damages are caused by a fire, lightning strike, flooding or other natural disasters;
- there are alterations to the construction or configuration of the product, or repair was performed by an unauthorized person;

- the product has mechanical damages, traces of damages caused by chemical substances;

- the product was operated with violation of the requirements specified in this Manual;

- warranty does not cover parts made of glass and light sources, consumable materials.

- if the product was delivered to the buyer by transport that does not belong to the manufacturer, the manufacturer will not accept claims related to quality, completeness and mechanical damages.

- manufacturer does not guarantee compatibility of the purchased product with the Buyer's equipment.

- manufacturer is not obliged to accept back properly functioning product if it did not suit the Buyer for any reason.

- if specialists from the manufacturing plant or specialized organization authorized to perform warranty repairs establish facts that point at the Buyer's fault in breakdown of the product, the Buyer shall pay all costs that the organizations mentioned above have incurred in dispatching their specialists. The obligation to prove guilt in this case lies on the Buyer.

- should any of the paragraphs listed above be violated, the manufacturer shall be entitled to terminate the warranty immediately without additional notification.

 ***Attention! This warranty does not limit the consumers' rights granted by the current law. After expiration of the warranty period the manufacturer shall not bear responsibility for the sold product.***

If you have any problems with operation of the product we recommend to get preliminary technical consultation from the service center specialists by phone _____ or by e-mail _____.

 ***Attention! Any intervention in the construction of the product during the warranty period is only allowed for service center specialists or certified contractors. Intervention by other service organizations requires written permission (authorization) from the manufacturing plant. Otherwise, validity of the warranty will be terminated.***

 ***Attention! IN CASE OF FAILURE TO FOLLOW THIS INSTRUCTION IN THE PART RELATED TO CONNECTION AND OPERATION OF THE PRODUCT THE MANUFACTURER RESERVES THE RIGHT TO REFUSE THE WARRANTY OBLIGATIONS!***

DISPOSAL

Materials used for packaging of refrigeration equipment can be completely processed and reused if taken to a recycling station.

 ***Attention! Do not allow children play with packing materials, since there is a hazard of suffocating if trapped inside the cardboard box or packing film.***

Refrigeration equipment requiring disposal should be taken to non-operating condition by cutting off the power cord, and then disposed of in accordance with the current national laws.

Refrigerant contained in the refrigeration system must be disposed of by a specialist. Need to pay attention and make sure that refrigeration system tubes are not damaged before disposal.

PRODUCT DRAWING

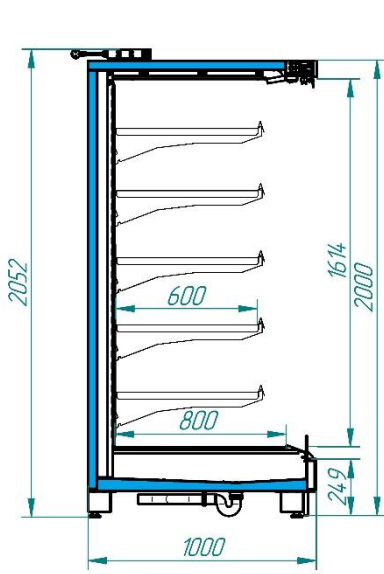

Neman Q H1

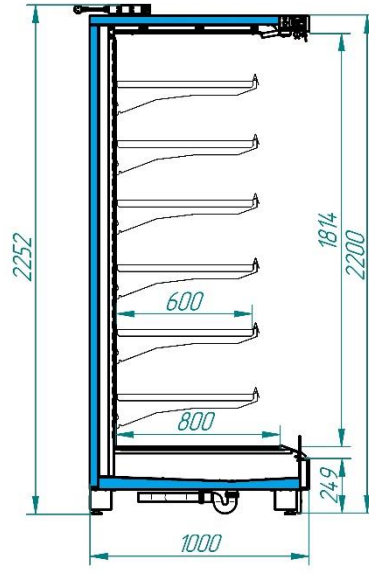

Neman Q H2

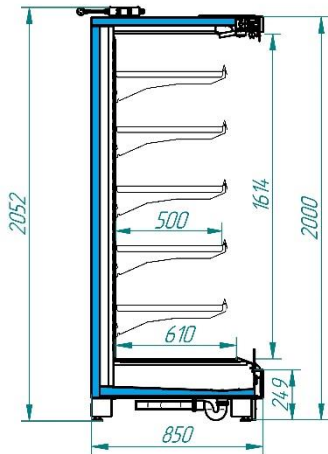

Neman Q slim H1

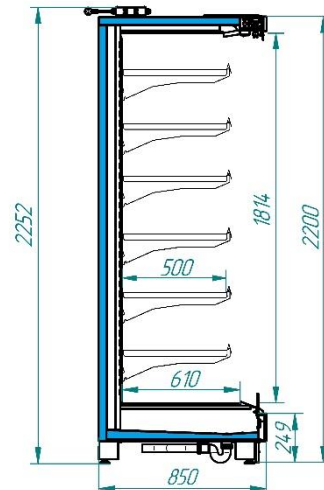

Neman Q slim H2

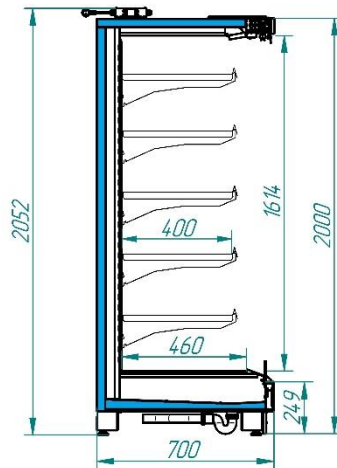

Neman Q X-slim H1

ELECTRIC DIAGRAM

Neman Q 125	A3.1	A7.1	XT2	M1 + M2
Neman Q 188	A3.1 + A3.2	A7.1 + A7.2	XT2 + XT3	M1 + M2 + M3
Neman Q 250	A3.1 + A3.2	A7.1 + A7.2 + A7.3	XT2 + XT3	M1 + M2 + M3 + M4
Neman Q 375	A3.1 + A3.2 + A3.3	A7.1 + A7.2 + A7.3 + A7.4	XT2 + XT3 + XT4	M1 + M2 + M3 + M4 + M5 + M6

Pos. description	Name	Q-ty	Remarks
A1	Controller	1	
SA1	Power switch	1	green
SA2	Light switch	1	yellow
BK1	Evaporator temperature sensor	1	
BK2	Inside volume temperature sensor	1	
A2	Control unit	1	
XS2	Clip connector in insulator OK 408/ 3M	1	
XP2	Clip connector in insulator OK 408/ 3F	1	
PE	Grounding according to GOST 21130-75	4	
A3	Light panel	1	
A3.1, A3.2, A3.3	LED lamp T8		Table 2
A4	Connection unit	1	
QF1	Two-pole automatic circuit breaker	1	
XT1	Transformer terminal block for 6 contacts OK 508 F_F	7	
XP1	Power cord plug	1	
A5	Evaporator	1	
EK1	Evaporator defrost heater	1	
X1, X2	Connection GSI 1.5	2	
A6	Solenoid coil	1	
A7	Fan panel		Table 2
XT2, XT3, XT4	Transformer terminal block for 6 contacts OK 508 F_F		Table 2
M1,..., M6	Fan panel motors		Table 2

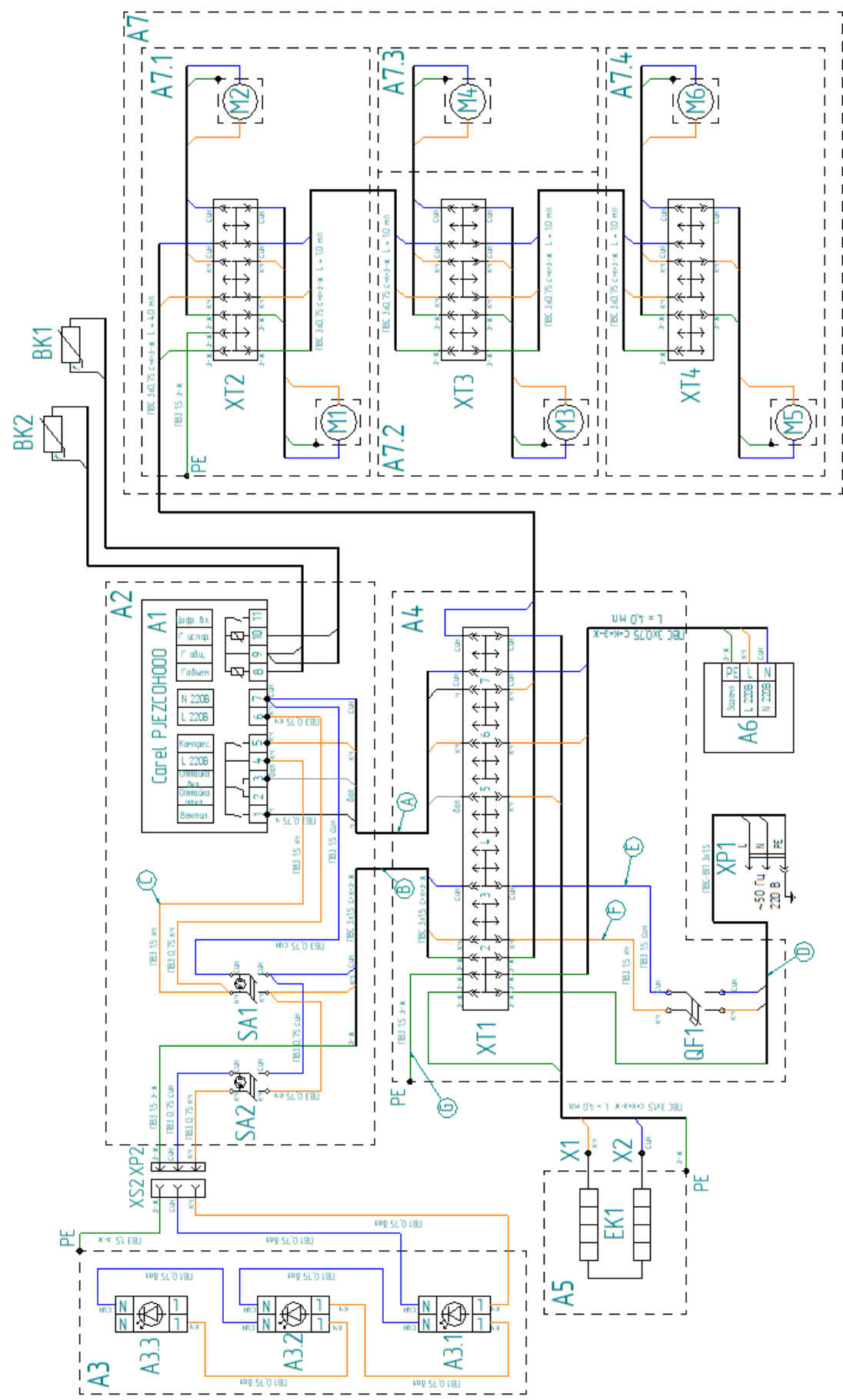

ACCEPTANCE CERTIFICATE

Product, factory No. _____, corresponds to the technical specification and is declared fit for operation, packaged by the manufacturer according to the technical documentation.

Electrical wiring of the product is designed for 230 V.

Date of production _____

Refrigeration compressor _____ No. _____,

Packer No. _____

Responsible for acceptance _____ /
(signature/name)

LS

PRODUCT COMMISSIONING STATEMENT

This Statement is prepared by the product owner

(organization name and address)

(position, full name of organization's representative)

and representative of service organization

(organization name and address)

(position, full name of organization's representative)

(identification document No., by whom and when issued)

(affix personal stamp here)

certifies that the product

(name of product)

factory No. _____, with refrigeration compressor
_____ No. _____, purchased on
" ___ " _____ 20___ from _____,
(organization name)

city _____, telephone _____,

was put into operation and accepted for maintenance in accordance with agreement

No. _____ dd. " ___ " _____ 20___ between the product owner and
organization _____

Statement prepared and signed

Product owner

Representative of organization
putting the product
into operation

(signature)

(signature)

" ___ " _____ 20___

LS

LS

MAINTENANCE RECORDS

Date	Type of maintenance	Position, last name and signature	